



iOS App Store



Google play

GoodWe(China)

No.189 Kunlunshan Rd., SND,
Suzhou, 215163, China

T: 400 998 1212

service.chn@goodwe.com.cn

www.goodwe.com.cn

GoodWe(Netherlands)

Franciscusdreef 42C
3565AC Utrecht

T: + 316 1988 6498

service.nl@goodwe.com.cn

www.goodwe.com.cn

GoodWe(Australia)

19 Fairleigh Street, Glenroy,
VIC, 3046, Australia

T: +613 9324 0559

service.au@goodwe.com.cn

www.goodwe.com.cn

GoodWe(UK)

46 Foyle Road London
N17 ONL United Kingdom

T: + 44 (0)333 358 3184

service@goodwe.co.uk

www.goodwe.co.uk

Note: The contact information above is subject to change without notice. please refer to the company's website at www.goodwe.com.cn.



EM SERIES USER MANUAL



HYBRID INVERTER

340-00053-00

1 Introduction	01
-----------------------	----

2 Important Safety Warning	
2.1 Symbols	01
2.2 Safety	02

3 Installation	
3.1 Packing List	03
3.2 Product Overview	04
3.3 Selecting The Mounting Location	04
3.4 Mounting	05

4 Electrical Connection	
4.1 PV Connection	06
4.2 Battery Connection	08
4.3 On-grid & Back-up Connection	09
4.4 EzMeter & CT Connection	11
4.5 Communication Connection	12
4.6 Wi-Fi Connection	13
4.7 Wi-Fi Reset & Reload	13
4.8 DRED Connection	13
4.9 Earth Fault Alarm	14
4.10 System Connection Diagram for Australia	14
4.11 Off-grid System Connection Diagram	14
4.12 special backup application	15

5 EzManage Illustration	15
--------------------------------	----

6 CEI Auto Test introduction	16
-------------------------------------	----

7 LED Lights Illustration	18
----------------------------------	----

8 Work Modes	19
---------------------	----

9 Trouble shooting	20
---------------------------	----

10 Error Messages	24
--------------------------	----

11 Technical Parameters	25
--------------------------------	----

12 Certificates	27
------------------------	----

1 Introduction

The EM series inverters (hybrid) are bidirectional which apply to PV system with battery to store energy. Energy produced by the PV system is used to optimize self-consumption; excess energy is used to charge the batteries, and then feed into the public grid when the PV energy is adequate, When PV energy output is insufficient to support connected loads, the system automatically discharge energy from the batteries if battery capacity is abundant. If the battery energy is insufficient to meet own consumption requirements, electricity will be drawn from the public grid. The EM series inverter is design for both indoor and outdoor use.

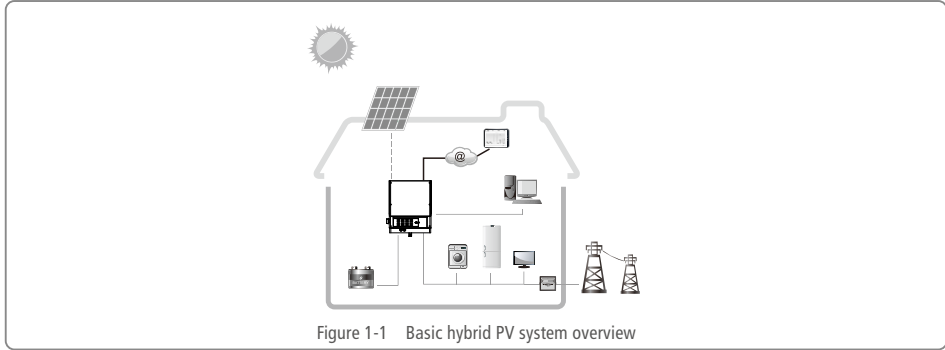

Figure 1-1 Basic hybrid PV system overview

2 Important Safety Warning

Before using the inverter, please read all instructions and cautionary markings on the unit and this manual. Store the manual where it can be accessed easily. The EM series inverter of Jiangsu GoodWe Power Supply Technology Co. Ltd. (hereinafter referred to as GoodWe) strictly conforms to related safety rules in design and test. Safety regulations relevant to the location shall be followed during installation, operation and maintenance. Improper operation may have a risk of electric shock or damage to equipment and property.

2.1 Symbols

	Caution! Failure to observe a warning indicated in this manual may result in injury.		Components of the product can be recycled.
	Danger of high voltage and electric shock!		This side up; the package must always be transported, handled and stored in such a way that the arrows always point upwards.
	Danger of hot surface!		No more than six (6) identical packages may be stacked on each other.

	Product should not be disposed as household waste.		The package/product should be handled carefully and never be tipped over or slung.
	Refer to the operating instructions		Keep dry; the package/product must be protected from excessive humidity and must be stored under cover.
	Signals danger due to electrical shock and indicates the time (5 minutes) to allow after the inverter has been turned off and disconnected to ensure safety in any installation operation.		CE Mark

2.2 Safety

- Installation, maintenance and connection of inverters must be performed by qualified personnel, in compliance with local electrical standards, wiring rules and the requirements of local power authorities and/or companies (for example : AS 4777 and AS/NZS 3000 in Australia).
- To avoid electric shock, DC input and AC output of the inverter must be terminated at least 5 minutes before performing any installation or maintenance.
- The temperature of some parts of the inverter may exceed 60°C during operation. To avoid being burnt, do not touch the inverter during operation. Let it cool before touching it.
- Ensure children are kept away from inverters.
- Do not open the front cover of the inverter. Apart from performing work at the wiring terminal (as instructed in this manual), touching or changing components without authorization may cause injury to people, damage to inverters and annulment of the warranty.
- Static electricity may damage electronic components. Appropriate method must be adopted to prevent such damage to the inverter; otherwise the inverter may be damaged and the warranty annulled.
- Ensure the output voltage of the proposed PV array is lower than the maximum rated input voltage of the inverter; otherwise the inverter may be damaged and the warranty annulled.
- When exposed to sunlight, the PV array generates dangerous high DC voltage. Please operate according to our instructions, or it will result in danger to life.
- PV modules should have an IEC61730 class A rating.
- If the equipment is used in a manner not specified by the manufacturer, the protection provided by the equipment may be impaired.
- Completely isolate the inverter before maintaining. Completely isolate the inverter should : Switch off the DC switch, disconnect the PV terminal, disconnect the battery terminal, and disconnect the AC terminal.
- Prohibit to insert or pull the AC and DC terminals when the inverter is running.
- In Australia, the inverter internal switching does not maintain the neutral integrity, neutral integrity must be addressed by external connection arrangements like the example proposed in the diagram 4.10.
- In Australia, the output of backup side in switchbox should be labeled 'main switch UPS supply', the output of normal load side in switchbox should be labeled 'main switch inverter supply'.

● Don't connect EM series in the following ways:

- ① Back-up port should not be connected to grid;
- ② Back-up port should not be connected in parallel;
- ③ The single PV panel string should not be connected to two or more inverters.

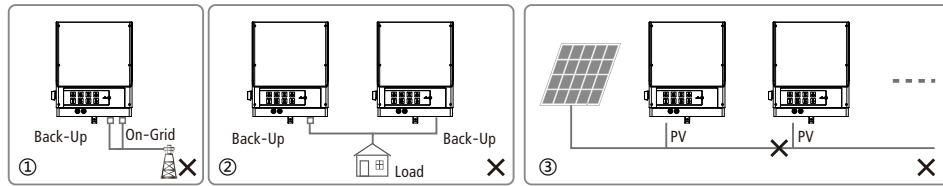

3 Installation

3.1 Packing List

Before installation, please inspect the unit. Be sure that nothing inside the package is damaged. You should have received the following items inside of package:

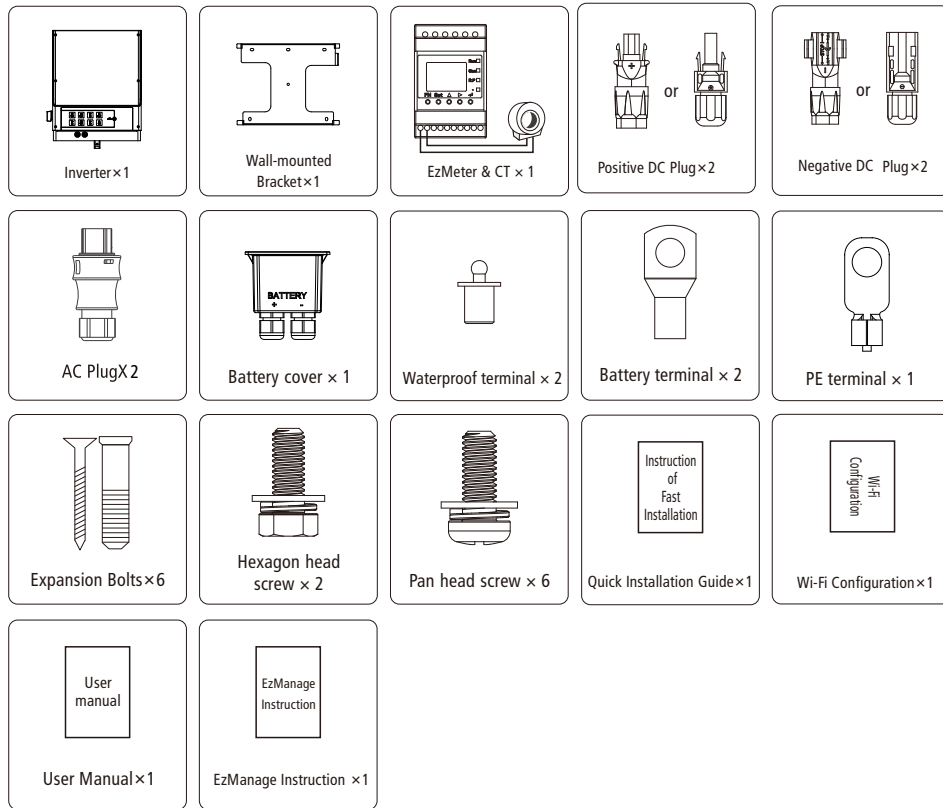

3.2 Product Overview

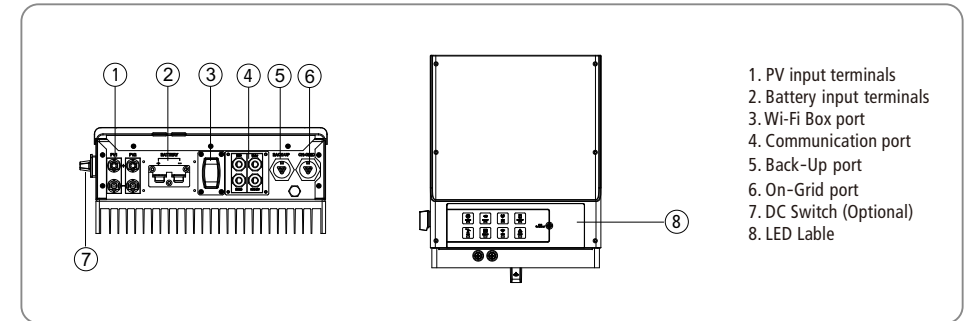

3.3 Selecting The Mounting Location

Mounting location should be selected based on the following aspects:

- The installation method and mounting location must be suitable for the inverter's weight and dimensions.
- Mount on a solid surface.
- Select a well ventilated place sheltered from direct sun radiation.
- Install vertically or tilted backward by max 15°. The device cannot be installed with a sideways tilt. The connection area must point downwards. Refer to Figure 3.3-1.

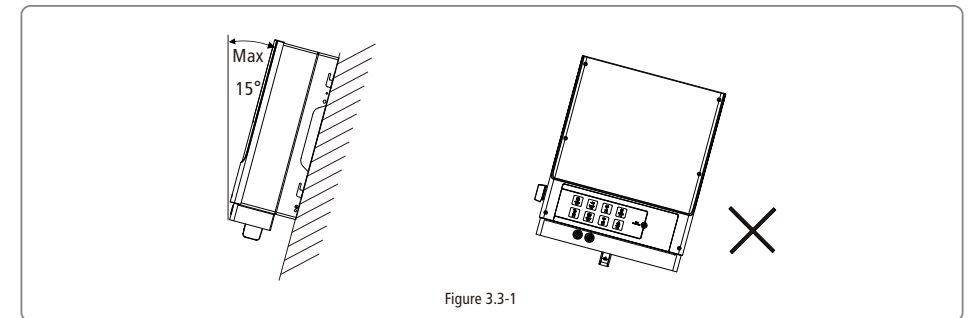

- In order to achieve optimal performance, the ambient temperature should be lower than 45 °C.
- For the convenience of checking the LED lights and possible maintenance activities, please install the inverter at eye level.
- Inverters should NOT be installed near inflammable and explosive items. Any strong electro-magnetic equipment should be kept away from installation site.
- Product label and warning symbol shall be clear to read after installation.
- Please avoid direct sunlight, rain exposure, snow lay up when install.

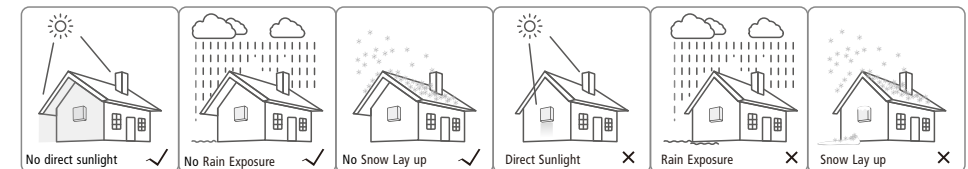

- In consideration of heat dissipation and convenient dismantlement, the minimum clearance around the inverter should be no less than the following value:

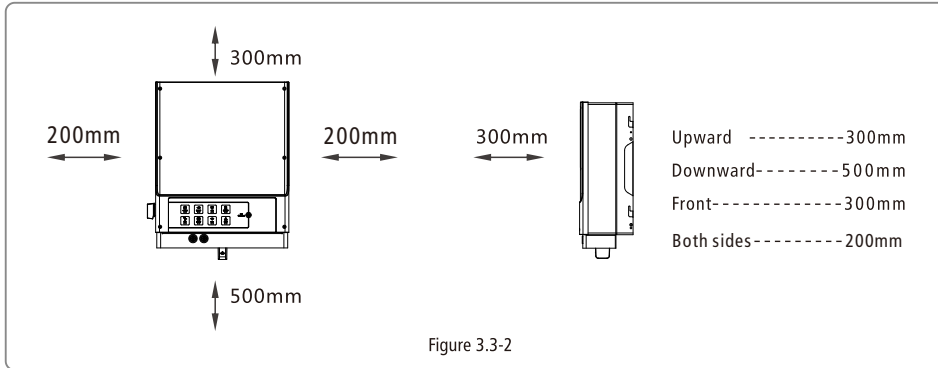

3.4 Mounting

Remember that this inverter is heavy! Please be careful when lifting out from the package.

1. Use the wall-mounted bracket as a template and drill 6 holes on the wall, 10 mm in diameter and 80 mm deep. Refer to Figure 3.4-1.
2. Fix the wall-mounted bracket on the wall with six expansion bolts in accessory bag.
3. Carry the inverter by holding the heat-sink two sides. Refer to Figure 3.4-2.
4. Place the inverter on the wall-mounted bracket. Refer to Figure 3.4-3、 Figure 3.4-4.

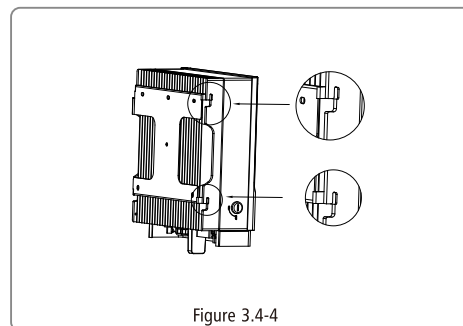
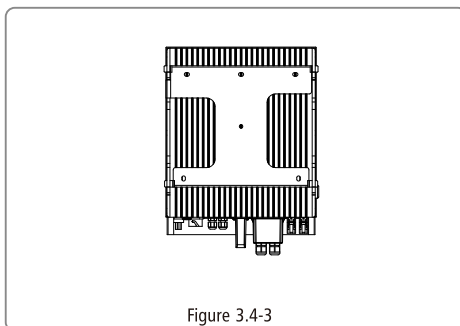
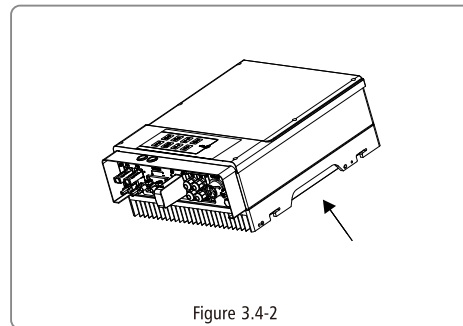
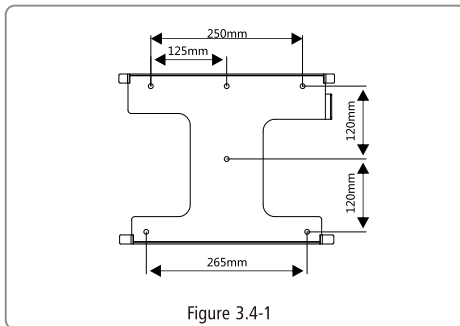

4 Electrical Connection

Hybrid Inverter System Connection Diagram

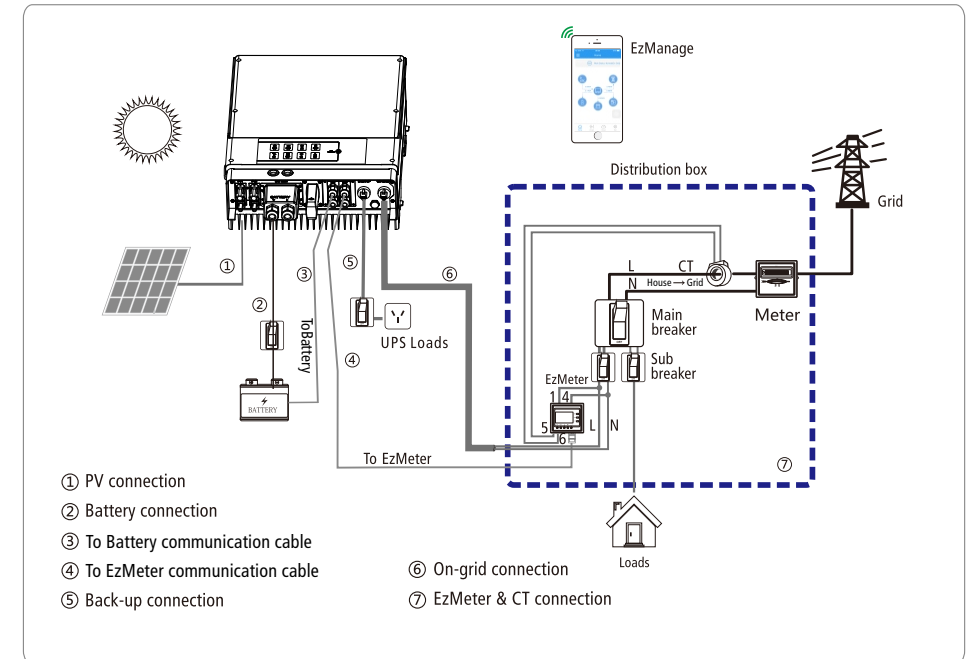

Note: if equipped with lead-acid battery, do not need to connect ③.

4.1 PV Connection

- Before connecting the PV panels, ensure the plug connectors have the correct polarity. Incorrect polarity could permanently damage the inverter.
- Check the short-circuit current of the PV string. The total short-circuit current must not exceed the inverter's maximum PV current.
- PV array should not be connected to the grounding conductor.
- Must be use DC plugs in accessory bag.
- The minimum insulation resistance to ground of the PV pannels must exceed 19.33kΩ, there is a risk of shock hazard if the requirement of minimum resistance is not met.

There are two types of DC plugs, Phoenix and MC4 or Amphenol series. Please refer to Figure 4.1-1.

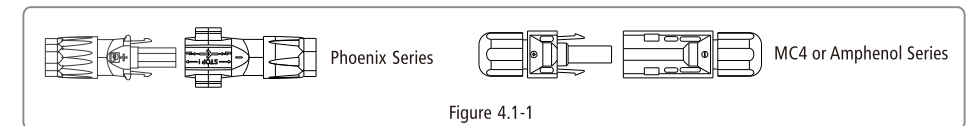

Installation instruction of Phoenix please refer to Figure 4.1-2.

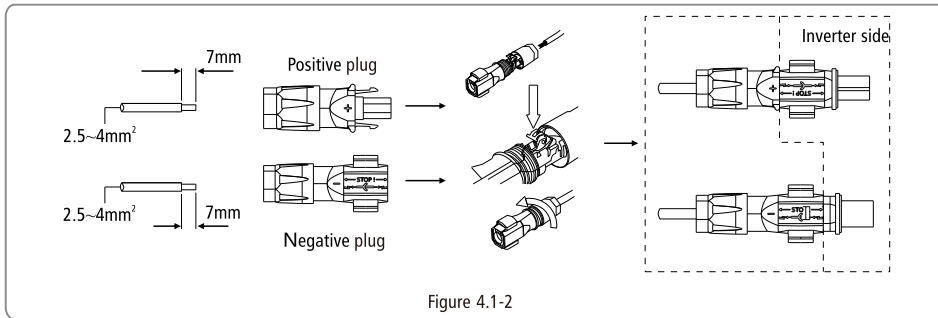

Figure 4.1-2

Installation instruction of MC4 and Amphenol please refer to Figure 4.1-3.

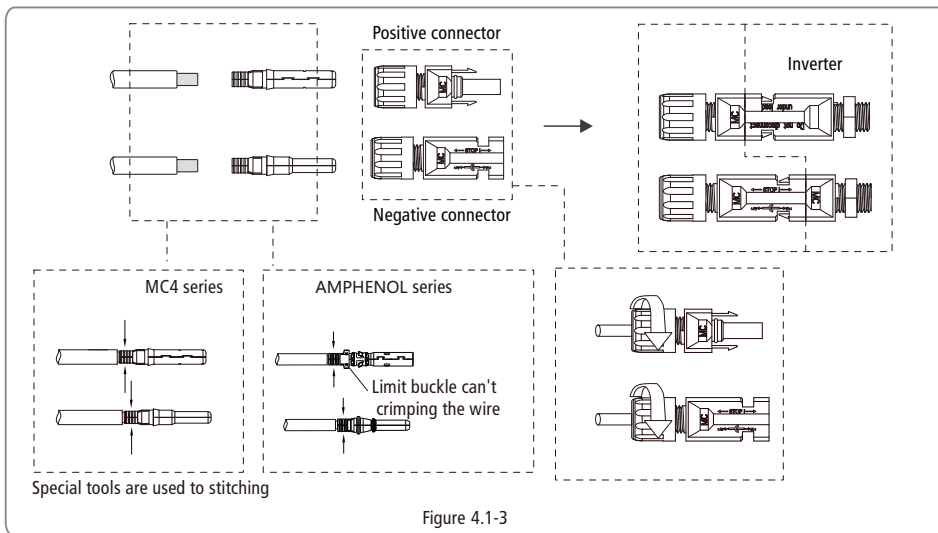

Figure 4.1-3

An earth wire terminal is set on the left side of the inverter. If necessary, it can be connected to earth wire. Refer to Figure 4.1-4

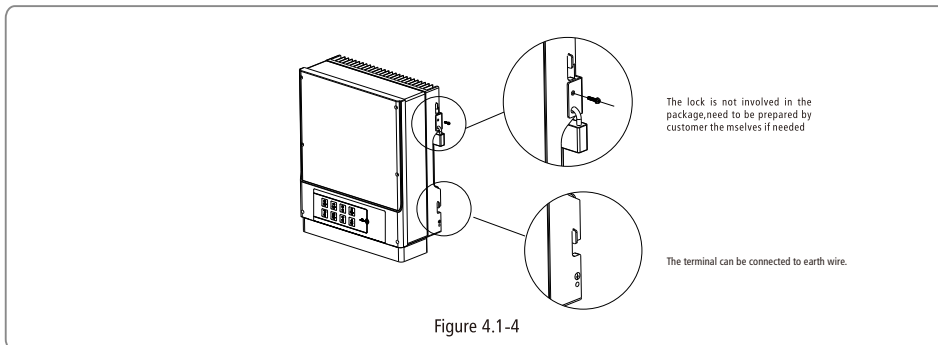

Figure 4.1-4

4.2 Battery Connection

Before connecting to battery, please install a separate DC breaker (63A) between inverter and battery. This will ensure the inverter can be securely disconnected during maintenance.



• Reversed polarity will damage the inverter!

- Be aware of electric shock and chemical hazards!
- It is a normal phenomenon that electric arc occurs when connecting battery to the inverter without use a DC breaker.
- It's very important for system safety and efficient operation to use appropriate cable for battery connection. To reduce risk of injury, please use the proper recommended cable size. Refer to Figure 4.2-1.

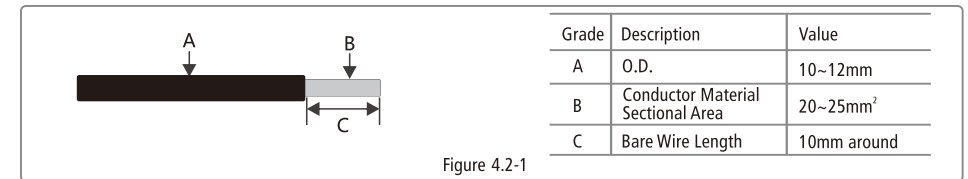

Figure 4.2-1

- Suggestion: if the battery is to be installed indoor, for details please refer to battery manufacture's user manual.
- Suggestion: Batteries must be installed with a distance to each other, details please refer to battery manufacture's user manual.
- As for the number of cells used, it will be decided by customer's choice, the choice must comply with the followed requirement: the rated voltage is 48V.

Please follow below steps to implement battery connection:

- (1) Check the nominal voltage of batteries. The nominal output voltage should meet GoodWe product Spec.
- (2) Disconnect DC breaker between inverter and battery.
- (3) Disconnect screw cap from insulator.
- (4) Disconnect waterproof ring from insulator.
- (5) Put the cable through the components in this order: screw cap, waterproof ring, insulator, battery cover and battery terminal. Refer to Figure 4.2-2.
- (6) Compress the terminal head by professional tool and screw down screw cap slight. Refer to Figure 4.2-3, Figure 4.2-4.
- (7) Put battery terminals into the corresponding holes (Red to the positive terminal; Black to the negative terminal.) and fasten them by screwdriver and spanner (recommended torsion:50~70Kg-f.cm), then fasten battery cover with pan head screws in accessory bag. Refer to Figure 4.2-5, Figure 4.2-6, Figure 4.2-7.
- (8) Screw down screw cap again.

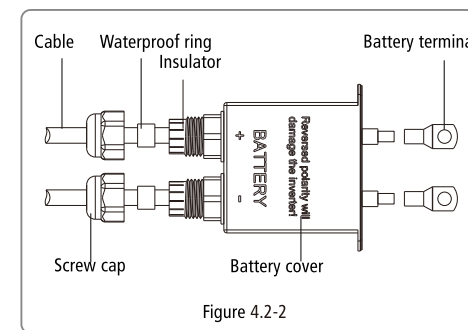

Figure 4.2-2

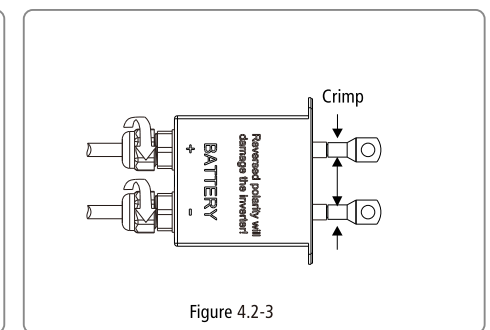
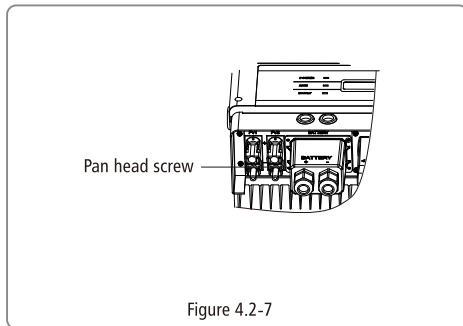
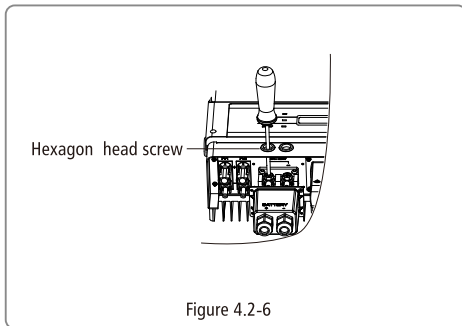
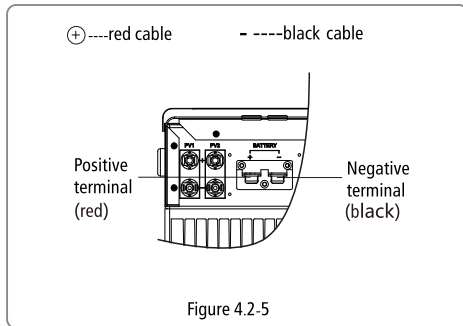
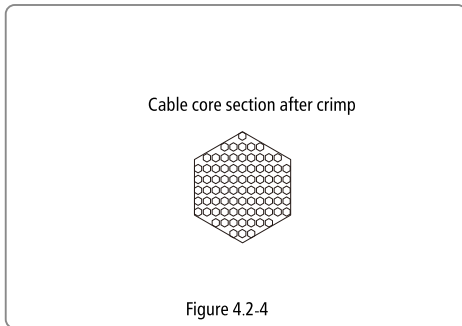

Figure 4.2-3



4.3 On-grid & Back-up Connection

4.3.1 On-grid Connection

In order to ensure that the inverter can be safe and reliable to disconnect from grid, please install a circuit breaker only for inverter on-grid port.

Model	Recommended circuit breaker specifications
GW5048-EM	32A
GW3648-EM	
GW3048-EM	

Note:

- Multiple inverters are not allowed to share a circuit breaker.
- Load is not allowed to connect between the inverter and the circuit breaker.

4.3.2 BACK-UP Load Connection

In order to ensure that the back-up function can be safe and reliable, Please refer to the following content, refer to left Figure 4.3.2-1.

Inductive load: Single inductive load max power ≤ 1 kVA, Total inductive load power ≤ 1.5 kVA;

For example :Such as Air conditioner, Washer, Electric motor etc is inductive load;

Capacitive Load : Single capacitive load power ≤ 0.7 kVA, Total capacitive load power ≤ 1.5 kVA;

For example :Such as computer, Switch power etc is capacitive load;

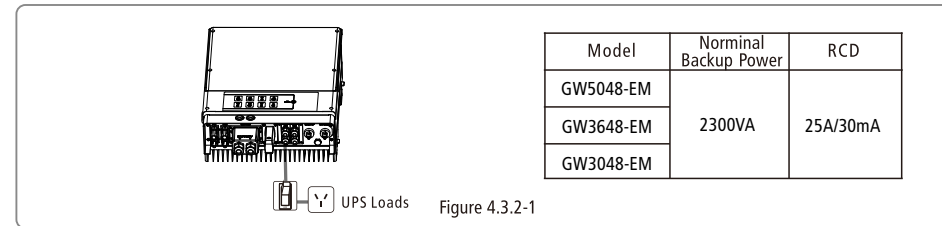

4.3.3 AC Terminal Connection

Installation instruction of WIELAND series please refer to Figure 4.3.3-1.

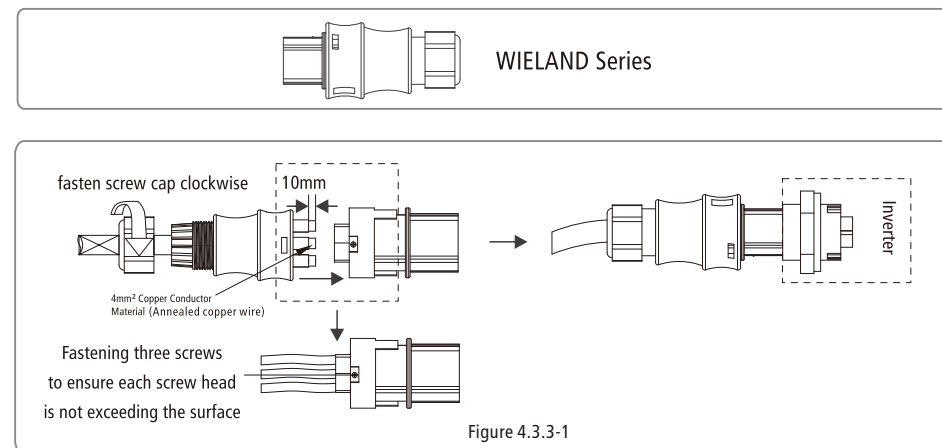

4.4 EzMeter & CT Connection

EzMeter can detect the grid voltage and the magnitude and direction of current, to control the working condition of hybrid inverter via RS-485 communication. For the connection method of EzMeter & CT refer to Figure 4.4-1.

Please follow below steps to implement the EzMeter & CT connection:

- (1) Connect the CT to the main 'L' line as the Figure 4.4-1, make sure that the CT direction is 'House → Grid'.
- (2) Connect the EzMeter to the random 'L' and 'N' line, as the figure. To power up the EzMeter and detect the grid voltage, make sure that '1' connect to 'L', '4' connect to 'N'.

For the connection method of Type 1 EzMeter refer to Figure 4.4-1.

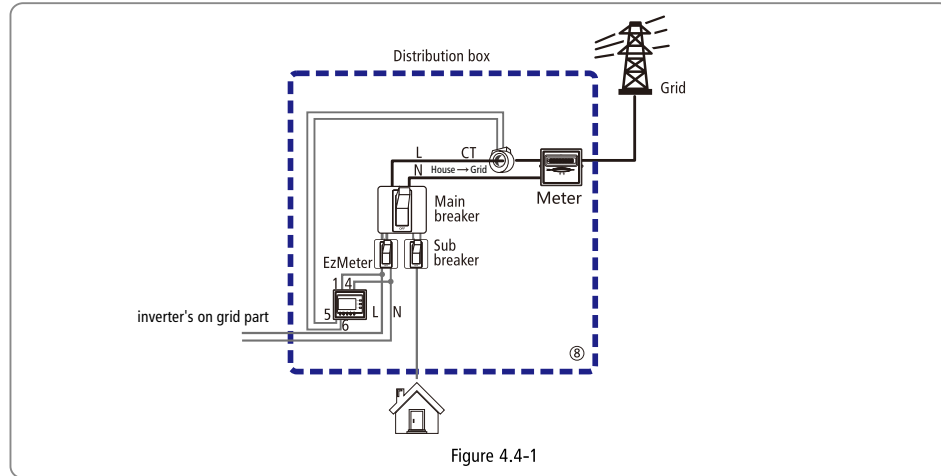

Figure 4.4-1

EzMeter LED light illustration

	OFF	ON	Blink
RUN	Not working	/	Working normal
Com(Red)	Not communicating	/	Communicating
R-P(Red)	Power Positive	Power Negative	/
----(Red)		Negative Value Indicator	/

EzMeter can work normally after installation, no configuration needed.

Users can see if communication is normal by checking if Com(Red) is blinking;

Make sure that the CT direction K L and L/N line connection is correct when installing EzMeter.

4.5 Communication Connection

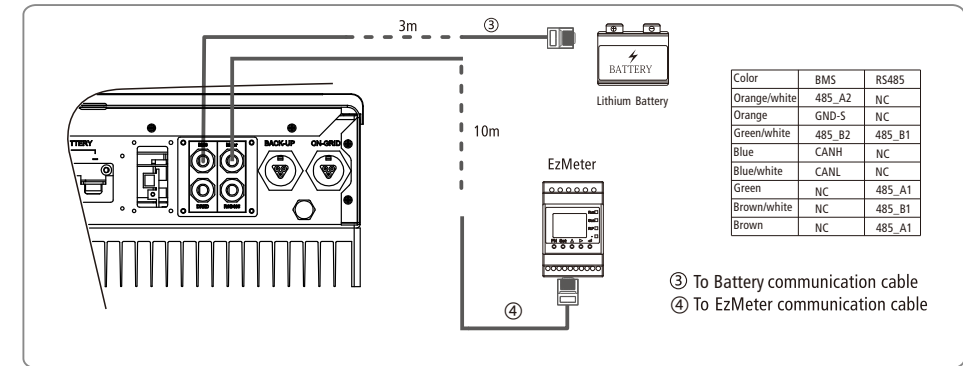

There are two pre-made cables connect to EM inverter, one cable is 3m which is marked "To Battery" should be connected to Li-battery communication port, the other cable is 10m which marked "To EzMeter" should be connected to EzMeter. If not use the battery communication and EM inverter is installed outside, please take out the "To Battery" cable by remove the communication cover, then put the communication cover back and install the waterproof terminal. The "To Meter" communication cable attached on inverter can be extended to max 100m, but for "to battery" cable, we do not suggest any extension.

BMS port is used for communication with lithium battery and can be used for both CAN and RS485 communication protocol.

RS485 port is used for communication with expansion devices.

4.7 Wi-Fi Reset & Reload

Wi-Fi Reset & Reload only apply to WiFi connection problem, such as 'can't find the inverter WiFi signal' or 'WiFi configuration problem'.

Wi-Fi Reset means restarting the Wi-Fi module.

Wi-Fi Reload means making the Wi-Fi module to the default factory setting.

- Short press (about 1s) the touch switch, then LED Wi-Fi displays Once a second flicker, Wi-Fi reset is successful. Refer to Figure 4.7-1.
- Long press (more than 3s) the touch switch, then Wi-Fi reload is successful. Refer to Figure 4.7-1.

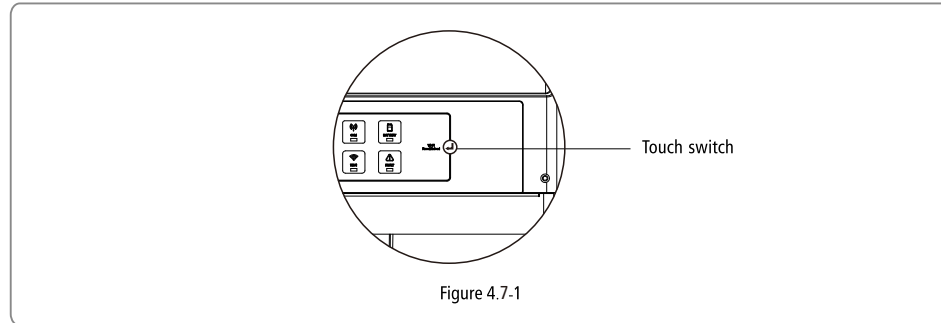

4.8 DRED Connection

Connection Procedure:

- Put the cable through the components in this order: screw cap, one-hole sealing ring, insulation body and sheet metal parts.
- Pull out the 6-pin terminal from the socket in the cabinet and take off the resistor which is fixed in it. Cable should be connected as Figure 4.8-1.
- Insert the green terminal into the corresponding interior terminal of the inverter. Pull cable softly to maintain the cable not to be pulled out.
- Lock the sheet metal parts onto the box and tighten the screw cap.

NOTE :

6-pin terminal is used to make connection to DRED device. If DRED device is not available, please keep it not connected.

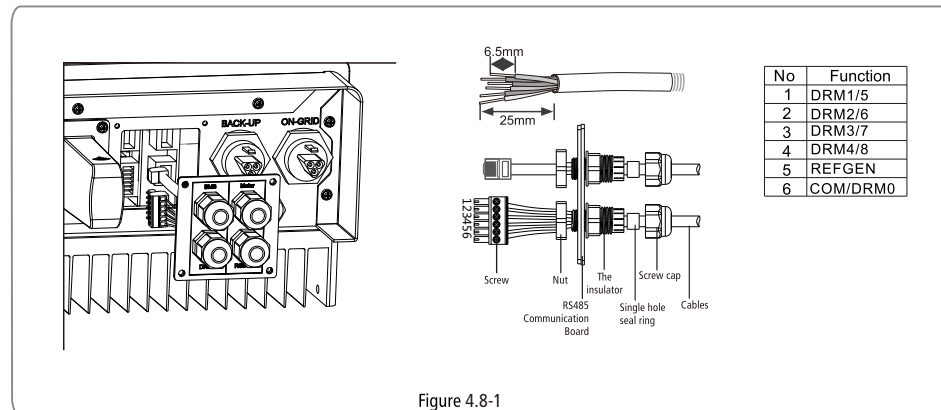

1. DRED connection is only available for Australia and New Zealand

2. Supported DRM command: DRM0, DRM1, DRM2, DRM3, DRM4, DRM5, DRM6, DRM7, DRM8

4.9 Earth Fault Alarm

Inverter complies with part 2 of IEC62109-2 13.9. When earth fault occurs, the fault indicator LED on front cover will light on and the buzzer in inverter will keep ringing 1 minute and ring again after half an hour unless the fault is eliminated.

4.10 System Connection Diagram for Australia

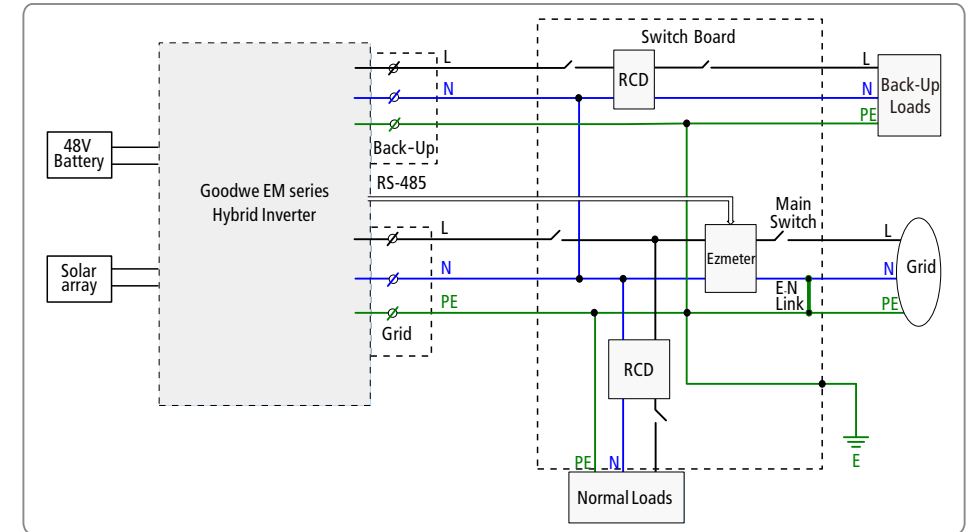

4.11 Off-grid System Connection Diagram

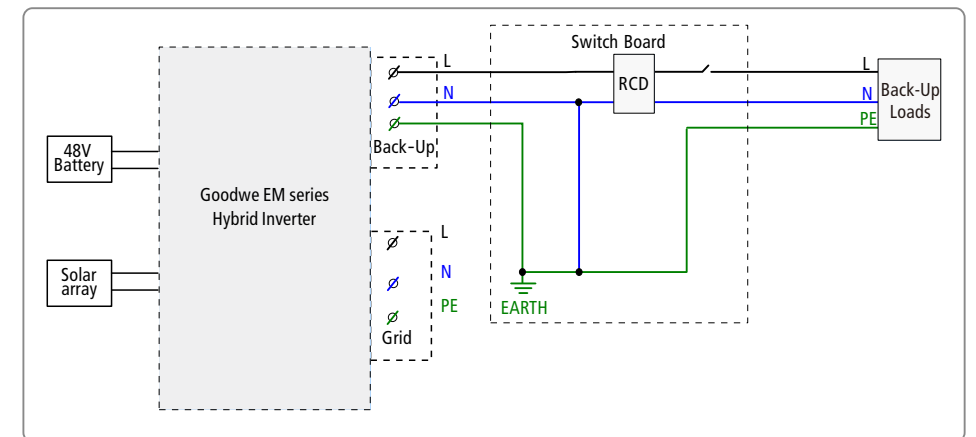

4.12 Special Back-up Connection

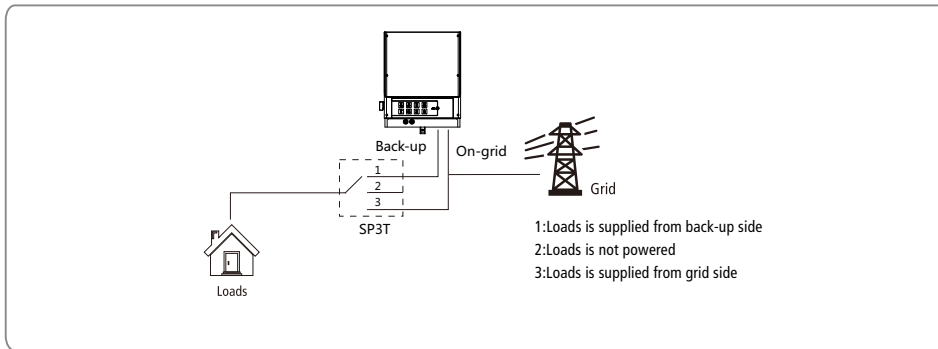

If need maintenance on EM, then just switch SP3T to position 3 as shown above. Thus the loads will be supplied by grid (loads supply will not be cut off).

5 EzManage Illustration



EM Series inverter has no LCD screen, it can be controlled via the APP software (EzManage). For iOS System, please go to AppStore to search for "EzManage", then download and install it. For Android System, please go to google play to search for "EzManage", then download and install it. Besides, it can be also installed by scanning the QR code on the back cover of this manual.

When EM hybrid inverter is working, please use mobile devices to select the SSID of inverter (Factory defaults is Solar - Wi-Fi, and initial password is 12345678. If any questions, please refer to Wi-Fi Configuration). After accessing inverter's Wi-Fi network, you can open the App then configure and monitor the EM system.

6 CEI Auto Test/Power limit function Introduction

The PV Auto Test function of CEI is integrated in EzManage App. For the detailed operation of this function, please check instructions on EzManage App.

You can set Power limit function by EzManage APP. For the detailed operation of this function, please check instructions on EzManage App.

7 LED Lights Illustration

SYSTEM	BACK-UP	COM	BATTERY	GRID	ENERGY	Wifi	FAULT
Green	Green	Blue	Blue	Blue	Yellow	Yellow	Red

INDICATOR	STATUS	EXPLANATION
SYSTEM		ON = SYSTEM IS READY
		BLINK = SYSTEM IS STARTING UP
		OFF = SYSTEM IS NOT OPERATING
BACKUP		ON = BACK-UP IS READY / POWER AVAILABLE
		OFF = BACK-UP IS OFF / NO POWER AVAILABLE
COM		ON=BMS AND METER COMMUNICATION OK
		BLINK1= METER COMMUNICATION OK, BMS COMMUNICATION FAIL
		BLINK2= BMS COMMUNICATION OK, METER COMMUNICATION FAIL
		OFF= BMS AND METER COMMUNICATION FAIL
BATTERY		ON = BATTERY IS CHARGING
		BLINK 1 = BATTERY IS DISCHARGING
		BLINK 2 = BATTERY IS LOW / SOC IS LOW
		OFF = BATTERY IS DISCONNECTED / NOT ACTIVE
GRID		ON = GRID IS ACTIVE AND CONNECTED
		BLINK = GRID IS ACTIVE BUT NOT CONNECTED
		OFF = GRID IS NOT ACTIVE
ENERGY		ON = CONSUMING ENERGY FROM GRID / BUYING
		BLINK 1 = SUPPLYING ENERGY TO GRID / ZEROING
		BLINK 2 = SUPPLYING ENERGY TO GRID / SELLING
		OFF = GRID NOT CONNECTED OR SYSTEM NOT OPERATING
Wi-Fi		ON = Wi-Fi CONNECTED / ACTIVE
		BLINK 1 = Wi-Fi SYSTEM RESETTING
		BLINK 2 = Wi-Fi ROUTER PROBLEM
		BLINK 4 = Wi-Fi SERVER PROBLEM
		OFF = Wi-Fi NOT ACTIVE
FAULT		ON = FAULT HAS OCCURRED
		BLINK = OVERLOAD OF BACK-UP OUTPUT / REDUCE LOAD
		OFF = NO FAULT

8 Work Modes

EM series inverters have the following main work modes based on different conditions:

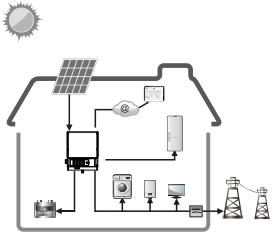
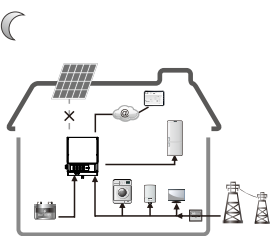
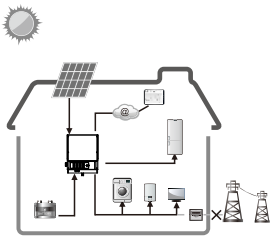
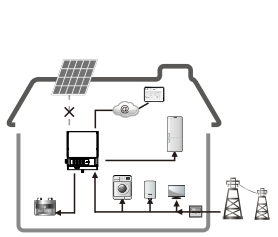
<p>Mode1 : Energy produced by the PV system priority for local load, excess energy is used to charge the battery, finally remaining is delivered to the grid.</p>	
<p>Mode2 : If there is no PV, battery energy is used for local load first, the grid also can supply when the battery capacity is not enough.</p>	
<p>Mode3 : If the grid is fault or there is no grid, the system can still work, PV and batteries supply energy for local load.</p>	
<p>Mode4 : The battery can be charged by the grid, time and power of battery charging can be set up flexibly.</p>	

9 Trouble shooting

Q/A and Trouble Shooting on EM			
(+/-) not reversed	PLEASE CHECK THE FOLLOWING ITEMS AT THE FIRST INSTALLATION, MAKE SURE EVERYTHING IS FINE. OR PLEASE STOP INVERTER SYSTEM TILL EVERY THING CONFIRMED FINE OR CONTACT GOODWE.		
	Checking Items	Checking Description	
	Check items before EM start-up	Battery connection	Confirm the connection between EM and battery : polarity (+/-) not reversed
		PV INPUT connection	Confirm the connection between EM and PV panels : polarity (+/-) not reversed
		AC OUTPUT Connection	Confirm ON-GRID connected to power grid and Back-up to loads : polarity (+/-) not reversed
EzMeter / CT connection		Make sure EzMeter & CT connected between house loads and grid. and follow the House → Grid direction sign on CT.	
Checking items when start up system	EzMeter Communication check	<p>Checking details :</p> <ol style="list-style-type: none"> 1. Check if the COM led on EzMeter triple blinking or not. 2. Or connect Solar-Wifi, check in EzManage App ("Parameters") if EzMeter COM state is "OK" or not. If COM led does not blink, or show "NG" on App, then please check the connection between EzMeter and EM, like: <ol style="list-style-type: none"> 1. RJ45 port broken or not; 2. communication cable looses or broken? 3. EzMeter should connect to EM RS485 port. If everything is Ok, but problem still there, please contact GoodWe after-sales services. 	
	CT & EzMeter connection direction	<ol style="list-style-type: none"> 1. Turn off PV and open Loads, check if R-P led is solid or not. If "R-P" not solid, please check <ol style="list-style-type: none"> a. if CT or EzMeter connected in a wrong direction (the arrow on EzMeter & CT should point to grid); b. if connection between EzMeter and CT (port 1 and 4 on EzMeter) is OK or not. If both are OK but problem still there, please contact GoodWe after-sales services. 	
	BMS Communication	<p>NOTE: do not need check if it is Lead-acid battery. For lithium battery, please check following: Connect Solar-Wifi, check on EzManage APP (Parameter >>> Battery) if BMS status shows "BMS Communication OK" or not. If APP BMS Status on APP says "BMS Communication Failure", please reboot EM. if problem is still there, please check further:</p> <ol style="list-style-type: none"> a. check on EzManage APP (Basic Setting) if Battery type is right what you have or not, if not right, please set it right in "Basic Setting" b. Connection between battery and EM is OK or not; c. communication cable looses or broken? d. RJ45 port/cables broken or not; <p>If everything is Ok, but problem still there, please contact GoodWe after-sales services.</p>	

		Battery settings on APP	<p>1. For Lithium battery: connect Solar-Wifi, check on EzManage APP (Parameter >>> Battery) if Battery Mode is right what you have or not, if not right, please set it right in "Boost settings"</p> <p>2. For lead-acid battery: All the settings should comply with the parameter of the battery (GoodWe do not suggest the settings for lead-acid batteries)</p>
		Problems	Solutions
Problems During Operation		EM not start up with ONLY battery connected	<p>1. Make sure the voltage of battery is higher than 48V, otherwise battery cannot start EM up. If battery voltage is OK, but problem still there, please contact GoodWe after-sales services.</p>
		EM not start up with ONLY PV connected	<p>1. Make sure the voltage of PV is higher than 125V; If everything is OK, but problem still there, please contact GoodWe after-sales services.</p>
		There is no discharge or output from EM without PV or PV Power lower than Load Power	<p>Check items:</p> <p>1. Communication between EM and EzMeter is OK or not; 2. Make sure Meter power is higher than 150W? a. EM/battery will not discharge continuously unless Meter Power is higher than 150W; b. If Meter Power is higher than 150W, but EM/Battery still not discharge, then please check Ezmeter & CT connection and direction;</p> <p>1. Make sure SOC is higher than 1-DOD ; Or if battery discharged to below 1-DOD, than battery will only discharge again when SOC charged to 20%+(1-DOD)/2 and SOC >105%-DOD(if need battery discharge immediately, customer can restart the system)</p> <p>2. Check on APP if it is set as charge time, during charge time, battery will not discharge (battery will charge preferentially during coincident time of charge/discharge) If everything is OK, but problem still there, please contact GoodWe after-sales services.</p>
		EM/Battery not charge when PV > P-load	<p>Check items:</p> <p>1. Check if charge voltage is properly set 2. Check if it is set as only charge time. 3. Check if battery is fully charged or not, or battery voltage reach "charge voltage" or not. If everything is OK, but problem still there, please contact GoodWe after-sales services.</p>
		Big Power fluctuation on Battery charge/discharge	Check items

		Big Power fluctuation on Battery charge/discharge	<p>Check items</p> <p>1. Check if there is a fluctuation on load power; 2. Check if there is a fluctuation on PV power on GoodWe Portal. If everything is OK, please contact GoodWe after-sales Services.</p>
		Battery change between Charge/discharge continually.	<p>Check items:</p> <p>1. Make sure battery settings are saved successfully; 2. Check if there is a fluctuation on PV power on GoodWe Portal If PV power is stable but problem still exist, please contact GoodWe services.</p>
		1. Battery does not charge	<p>Check items:</p> <p>1. Make sure BMS communication OK. if not, please try to restart EM, and check the connection (for lithium battery); 2. Check if EzMeter & CT connected in the right position and to right direction as on the user manual; 3. Check if total load power is much higher than PV power, or check if Pgrid on GoodWe Portal is always below 0W. If PV power is stable but problem still exist, please contact GoodWe services.</p>
Q/A (Questions and Answers)		Questions	Answers
		About Out-Put Power Limit	<p>1. Can set on APP the max out-put power to grid; 2. If Out-put Power Limit set as 0W, then there might still have max 100W to grid.</p>
		"Battery Activate" unction	<p>1. Open or close it on EzManage APP; 2. Used to activate battery when battery is discharged empty; 3. Only used when there is no battery charge.</p>
		Only use battery when grid is OFF	<p>1. On APP, Open off-grid output function and backup function; 2. Set charge time as 00:00-23:59, discharge time as default</p>
		On Portal, SOC has a sudden jump up to 95%?	<p>1. Happened on Lead-acid battery or when BMS communication NG on lithium battery; 2. if battery charge current keep lower than floating charge current set on APP for 30mins, SOC will be reset to 95% compulsively;</p>
		Battery cannot charge to 100%	<p>1. For LG battery, it will stop charge at SOC 95%. It is about LG battery, normal. 2. Battery will also stop charge when battery voltage reaches charge voltage set on EzManage APP.</p>
		Cannot see Solar-wifi signal on mobile devices	<p>1. Solar-wifi signal will disappear when EM connected to internet; if need change settings, can connect to customers' router to change. 2. If cannot see wifi signal when not connect to router, then please try to reload wifi (refer to EM user Manual) 3. If still cannot find wifi signal, then restart EM(disconnect everything including battery and PV/AC If cannot find Solar-wifi after all these try, please contact GoodWe after-sales services.</p>

Cannot save settings on EzManage APP	<ol style="list-style-type: none"> 1. Make sure you connected solar-wifi (make sure no other devices connected) or router (if connected Solar-wifi to router) and on home page shows connection OK. 2. Make sure EM under waiting mode (on APP) before you change any settings on EzManage APP ---- disconnect grid/load/battery, only leave PV connected and then restart EM till see work mode as wait on APP. If all these try does not help, please contact GoodWe services.
Battery switch trip	<ol style="list-style-type: none"> 1. For lithium battery, please make sure BMS communication OK; 2. Please check if battery voltage is lower than discharge voltage set on APP 3. Make sure no short-cut on Battery connection side.
Battery configuration	<ol style="list-style-type: none"> 1. Lithium battery must connect BMS communication; 2. Nominal voltage for Lead-acid battery is 48V, max charge voltage 60V; 3. For example, serial connection of 4*12V 100Ah lead-acid battery, the capacity will still be 100Ah.
Lithium battery connection	For connection of Ezconverter/battery and EM, please refer to battery connection SOP, chose right battery brand and fill in battery capacity manually.
Limitation on Backup Loads	<ol style="list-style-type: none"> 1. For Inductive Loads (like Air conditioner/wash machine/drill), the max power for each load should be lower than 1.5KAV , total power lower than 2.5KVA 2. For Capacitive Loads, the total max power should be lower than 3KVA
NO-ALLOWED connection	<ol style="list-style-type: none"> 1. Back-up side connected to grid; or backup side connect parallel; 2. Battery connected to grid; 3. One PV string connect to 2 or more PV inputs

10 Error Messages

An error message will be displayed on the APP if a fault occurs.

Table 8-1 is the Description of Error Message

Error message	Description
Utility Loss	Grid disconnected
Fac Failure	Grid frequency no longer within permissible range
PV Over Voltage	Overvoltage at DC input
Over Temperature	Overtemperature on the case
Isolation Failure	Ground insulation impedance is too low
Ground I Failure	Overhigh ground leakage current
Relay-Check Failure	Relay self-checking failure
DC Injection High	Overhigh DC injection
EEPROM R/W Failure	Memory chip failure
SPI Failure	Internal communication failure
DC Bus High	Overhigh BUS voltage
AC HCT Failure	Output current sensor failure
GFCI Failure	Detection circuit of ground leakage current failure
Vac Failure	Grid voltage no longer within permissible range
Battery Over Temperature	Battery Over Temperature
Battery Under Temperature	Battery Under Temperature
Battery Cell Voltage Differences	Li-Ion Battery Cell Voltage Differences
Battery Over Total Voltage	Li-Ion Battery Over Total Voltage
Battery Discharge Over Current	Battery Discharge Over Current
Battery Charge Over Current	Battery Charge Over Current
Battery Under SOC	Battery Capacity Low
Battery Under Total Voltage	Battery Under Total Voltage
Battery Communication Fail	Battery Communication Fail
Battery Output Short	Battery Output Short
Over Load	Back-up Output Over Load

Table 8-1

11 Technical Parameters

Model	GW3048-EM	GW3648-EM	GW5048-EM
Solar			
Max. allowed PV Power (W)	3900	4600	6500
Nominal DC power (W)	3000	4000	5500
Max. DC voltage (V)	550		
MPPT voltage range (V)	100~500		
Start feeding voltage (V)*	125		
Max. DC current (A)	11	11/11	
DC overcurrent protection(A)	13.8	13.8/13.8	
No. of DC connectors	1	2(can parallel)	
No. of MPPTs	1	2	
DC overvoltage category	Category II		
DC connector	MC4/ Phoenix/ Amphenol(Optional)		
Battery			
Battery Type	Lead-acid or Li-Ion		
Norminal Voltage (V)	48		
Max Charge Current (A)**	50		
Max Discharge Current (A)	50 (configurable)		
Battery capacity (Ah)***	>=50 (depending requirement)		
Charging curve	3-stage adaptive with maintenance		
Max Charge voltage (V)	60 (configurable)		
Battery temperature compensation	included(Li-Ion)		
Battery overcurrent protection(A)	63		
Battery voltage sense	integrated		
Current shunt	integrated		
AC Output Data (On-grid)			
Norminal AC power(VA)	3000	3680	5000****
Max. AC power(VA)	3000	3680	5000****
Max. AC current(A)	13.6	16	22.8****
AC overcurrent protection(A)	20	25	32
Norminal AC output	50/60Hz; 230Vac		
AC output range	45~55Hz/55~65Hz; 180~270Vac		
THDi	<3%		
Power factor	0.8 leading~0.8 lagging		
Grid connection	Single phase		
AC overvoltage category	Category II		
AC Output Data (Back-up)			
AC output (Back-up)	230Vac ±2%, 50Hz (60Hz Optional)±0.2%, THDv<3%(linear load),Single phase		
Max. AC current(A)	10		
Back-up overcurrent protection(A)	16		

Model	GW3048-EM	GW3648-EM	GW5048-EM
Norminal AC power(VA)	2300		
Peak power(VA)*****	3500, 10sec		
Efficiency			
Max. efficiency	97.6%		
Euro efficiency	>97%		
MPPT adaptation efficiency	99.9%		
Max Battery efficiency	94.5%		
Protection			
Residual current monitoring unit	Integrated		
Anti-islanding protection	Integrated		
DC switch(PV)	Integrated (optional)		
AC over current protection	Integrated		
Insulation monitoring	Integrated		
Certifications&Standards			
Grid regulation	VDE-AR-N 4105, AS4777.2, VDE0126-1-1, G83/G59, CEI 0-21,G100		
Safety	IEC62109-1&-2, IEC62040-1		
EMC	EN61000-6-1, EN61000-6-2, EN61000-6-3, EN61000-6-4, EN61000-3-2, EN61000-3-3		
General Data			
Dimensions (W*H*D)	347*432*145mm		
Weight (kg)	16	17	
Mounting	Wall bracket		
Ambient temperature range	-25~60°C		
Relative humidity	0~95%		
Max. operating altitude	4000m (> 3000m derating)		
Protection degree	IP65		
Cooling	Nature convection		
Noise emission(dB)	<25		
Display	LED, APP		
Communication	RS485;CAN;WiFi		

*: When there is no battery connected, Solar Start feeding voltage need more than 200V.

** : For lead-acid battery, default charge current is 0.15C, which is can be configurable up to 0.5C and cannot exceed 50A.

For Li-Ion battery, charge current follows the command of BMS which doesn't exceed 50A.

***: Under off-grid mode,then battery capacity should be more than 100 Ah.

****: 4600VA for VDE-AR-N4105, 21.7A for Australia and New Zealand

***** : Can be reached only if PV power is enough.

Note

Overvoltage category definition

Category I : applies to equipment connected to a circuit where measures have been taken to reduce transient overvoltage to a low level.

Category II : applies to equipment not permanently connected to the installation. Examples are appliances, portable tools and other plug-connected equipment;

Category III: applies to fixed equipment downstream of and including, the main distribution board. Examples are switchgear and other equipment in an industrial installation;

Category IV: applies to equipment permanently connected at the origin of an installation (upstream of the main distribution board). Example are electricity meters, primary overcurrent protection equipment and other equipment connected directly to outdoor open lines.

Moisture location category definition

Moisture parameters	Level		
	3K3	4K2	4K4H
Temperature Range	0~+40°C	-33~+40°C	-20~+55°C
Humidity Range	5%~85%	15%~100%	4%~100%

Environment category definition

Outdoor : the ambient air temperature is -20~50°C, Relative humidity range is 4 % to 100 %, applied to PD3

Indoor unconditioned: the ambient air temperature is -20~50°C, Relative humidity range is 5 % to 95%, applied to PD3

Indoor conditioned: the ambient air temperature is 0~40°C, Relative humidity range is 5 % to 85%, applied to PD2

Pollution degree definition

Pollution degree 1: No pollution or only dry, non-conductive pollution occurs. The pollution has no influence.

Pollution degree 2: Normally only non-conductive pollution occurs. Occasionally, however, a temporary conductivity caused by condensation must be expected.

Pollution degree 3: Conductive pollution occurs, or, dry, non-conductive pollution occurs which becomes conductive due to condensation which is expected.

Pollution degree 4: Persistent conductive pollution occurs, for example, the pollution cause by conductive dust, rain and snow.

12 Certificates



G100 IEC62109-1 IEC62109-2 CEI 0-21 VDE0126-1-1 VDE-AR-N 4105